



TCS9 Series

Time Controlled Level Switch

Installation and Operation Manual

Table of Contents

Description Of Operation	2
Installation	2
Safety Precautions.....	2
Included Components.....	3
Other Parts Required.....	3
Layout.....	3
Control Panel Mounting.....	3
Connections.....	5
Mains Supply 230Vac.....	5
Float Switch.....	5
Output to Controlled Devices (Load).....	6
Operation	6
Safety Precautions.....	6
Programming.....	7
Specifications	7

Description Of Operation

The TCS9 Time Controlled Level Switch is designed for tank level control applications such as the filling or emptying of a tank, controlled by a float or level switch but with the ability to limit activity by time or day (7 day timer), 20A switching capacity (more than a float switch alone), and without the voltage loss associated with long cable runs, allowing the float switch to be extended to very long distances without loss of performance at the connected appliance.

It is ideal for use with water and liquid storage tanks, liquid process applications, and other uses particularly where operation must be time restricted due to limited capacity, noise restrictions, etc.

Installation

Safety Precautions

Mains Voltage – There are exposed electrical conductors inside this appliance. This appliance must be installed and serviced by a competent electrical technician to the current requirements of BS7671 and IEEE recommendations. Before servicing this appliance, normal safe isolation procedures should be implemented.

Do not touch any connection terminals while energised.

Do not attempt to service this item when wet, or in a wet or high humidity environment.

If the housing of the control panel becomes damaged, you must shut down and securely isolate this appliance immediately.

Included Components

TCS9 Series Control Panel
Installation & Operation Manual
Timer User Instructions

Other Parts Required

Float switch or level switch
Screws or fixings to mount panel

Layout

The control panel cannot be mounted outside, it is not fully weather resistant, but can be installed in sheltered outdoor locations (barns, covered areas, etc).

Voltage drop will affect the cable size needed to take power to your appliances. The more current is drawn the greater the effect over distance. Over very long runs, you may find it more economical to install contactors near to the pumps, allowing you to control the pumps with a sensible cable size. It is strongly recommended that you calculate voltage drop for cable runs which exceed the length of cable supplied with the pump. Failure to do so may result in cable overheating, conductor migration, and risk of fire. The same caution applies to solenoid valves, although the current draw is usually so small that only extreme distances are likely to present a problem.

The float switch supplied is a 2 way float switch, it is set by default to close the circuit when the float is facing downwards. This suits the majority of tank re-filling applications. If desired it can be re-wired to close when the float is held upwards to suit tank drainage requirements. To do this the wiring within the plug attached to the float switch must be changed. The brown wire is common and connected to the voltage to be switched, blue returns voltage when the float is facing up and black returns voltage when the float faces downwards. Cables extension is straightforward using mains flex, but remember that all wires in use in a float switch carry live voltage, there is no neutral, and there is no earth or CPC, so suitable mechanical protection should be considered depending on cable routing. For the extension of float switch cables we recommend an IP68 cable joiner 3P Part number X20BKSD.

Suitable circuit protection must be installed and should include as a minimum a suitable earth, overcurrent protection, and residual current protection at 30mA, ideally on it's own circuit, but always in accordance with BS7671 and applicable regulations.

Control Panel Mounting

Open the cover of the control panel. There are 4 recesses, one on each corner of the panel. Drill

through at these locations and attach to the wall or a suitable support, taking care not to damage cabling inside the panel. Fixings are not included and should be selected to suit the material to which the panel will be mounted.

Connections

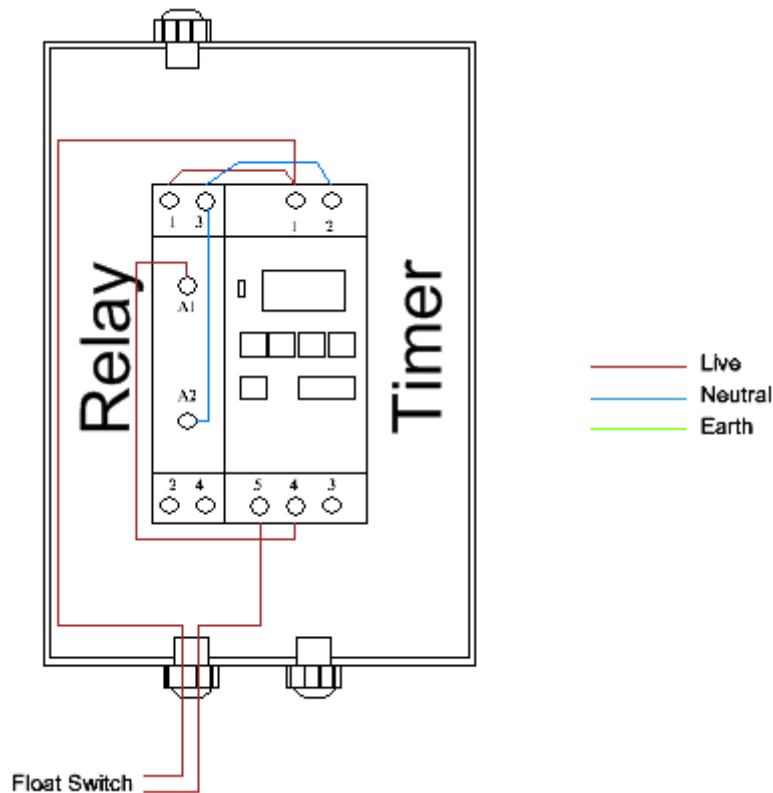

The control panel is supplied with wiring installed in the drawing shown above. The timer is always energised, and when programmed will output voltage via the float switch to the relay during the times set on the timer.

Mains Supply 230Vac

Attach the live conductor of the mains supply cable to relay terminal 1, ensuring the wire to the timer from this terminal also remains connected. Attach the neutral conductor of the mains supply to terminal 3 of the relay in the same manner. Leave the earth conductor long enough to connect to the wiring that will be attached at the bottom of the housing supplying the attached load (pump, etc).

Float Switch

Output to the float switch is pre-wired. In the event that the wiring need to be changed to activate the output with the float facing up then this should be done at the 3 pin plug attached to the float

switch. Brown and black are connected to the 2 outer pins, this closes the circuit when the float is down, but can be changed to brown and blue to operate the circuit when the float faces upwards. Operation can be verified by continuity testing.

Output to Controlled Devices (Load)

Connect the live conductor of the output to pin 2 of the relay, and connect neutral to pin 4 of the relay. Connect the earth conductor to the incoming earth conductor using the quick connector supplied, or by any preferred method. The output to the connected load switches both poles.

The drawing below shows the usual completed wiring layout.

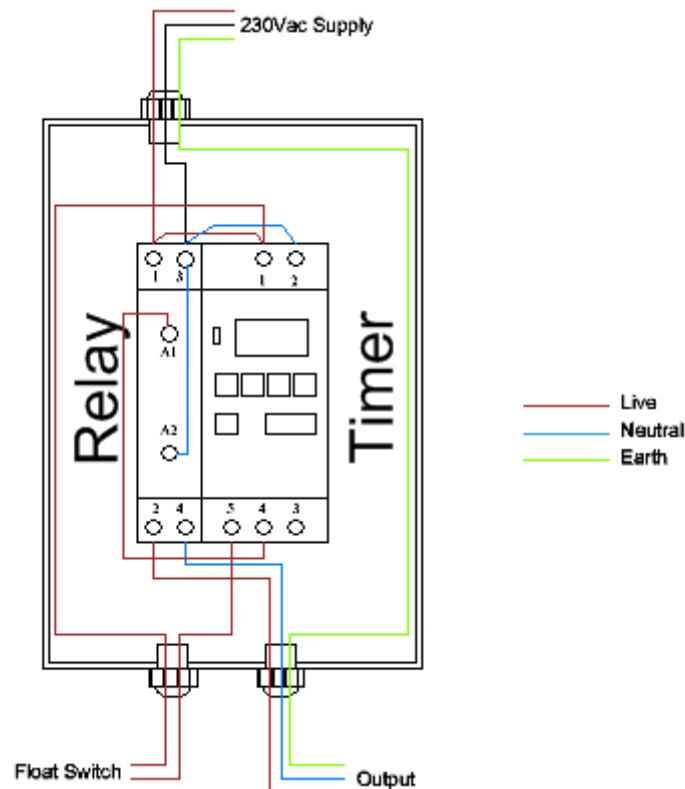

Operation

Safety Precautions

Mains Voltage – There are exposed electrical conductors inside this appliance. Before servicing this appliance, normal safe isolation procedures should be implemented.

Do not attempt to operate this item when wet, or in a wet or high humidity environment.

If the housing of the control panel or attached wiring becomes damaged, you must shut down and

securely isolate this appliance immediately.

Programming

The exact model of timer installed in this control panel may vary. Please refer to the included timer instructions for programming details.

Specifications

Dimensions: 120mm x 160mm x 90mm
Enclosure Material: ABS (Acrylonitrile Butadiene Styrene)
Ingress Protection: IP65
Timer: 7 day, multiple programs with manual override
Output: 230Vac 20A max (relay module)
Battery Backup Time: 200 hours approximately